



Rear Bumper Installation Instructions

P/N 210506.5: 2019+ Mercedes Sprinter Rear Bumper

Before you begin:

- *Stainless steel hardware may bind together when tightening — apply an anti-seize assembly lubricant to the threads of each bolt before assembly*
- *This installation requires two or more people*
- *Unless otherwise specified, refer to the general torque value at the end of the instructions for specified torque values*



Required Tools:

- Standard and metric wrench set
- Standard and metric socket set
- Flat head screwdriver
- Painter's Masking Tape
- Drill with a 5/32" drill bit

Included Hardware:

P/N	Description	Quantity
70185	7/16"-14 x 4-1/2" hex head bolt, grade 8	8
70056	7/16"-14 nylon-locking nut, grade 8	8
70057	7/16" washer	16
70060	1/4"-20 x 1" SS button head bolt	14
70009	1/4" ID washer	22
70010	1/4" star lock washer	6
70008	1/4"-20 nylon-locking nut	8
70432	3/8"-16 x 1" SS hex head bolt, serrated flange	2
70246	Antiseize bolt lubricant packet, 2g	1
70078	10-32 x 1" SS Counter Philips head	4
70005	SS No. 10 washer	4
70004	SS 10-32 Nylock Nut	4
70479	Bit, 5/32" hex, tamper-resistant	1
401132	1/4" Hex Bit Holder, Key Chain	1



Additional Parts:

Description

Quantity Picture

Trim assembly, driver (*pre-assembled*)

1

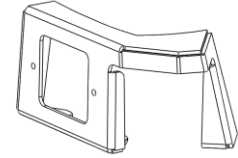

Trim assembly, passenger (*pre-assembled*)

1

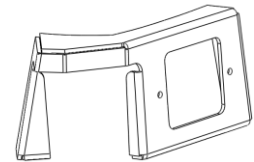

Axle support bracket, driver

1

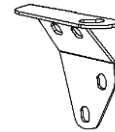

Axle support bracket, passenger

1

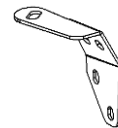

Blindspot assist sensor brackets (*pre-installed onto trim*)

2

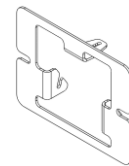

Blindspot assist sensor windows (*pre-installed onto trim*)

2

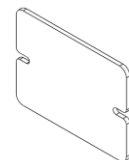



Stock Bumper Removal:

1. Remove license plate.
2. Remove stock hitch by unbolting the eight (8) bolts underneath the vehicle. Disconnect any wiring connected onto the hitch before lowering (towing plug, parking sensor, etc...). Reference Figure 1.

CAUTION: Unbolting will allow the hitch to fall if not properly supported.



Figure 1: Four (4) of the Hitch Mounting Bolts

PRO TIP: The entire installation is much easier if you lower and remove the spare tire. Then replace once complete or install onto your new bumper.

3. Remove the seven (7) torx bolts holding on the plastic rear bumper as indicated in Figure 2:



Figure 2: Torx Bolts on the Rear Bumper

4. Remove the two (2) plastic rivets holding on the plastic rear bumper from underneath the vehicle, close to the spare tire carriage. Reference Figure 3 and 4.

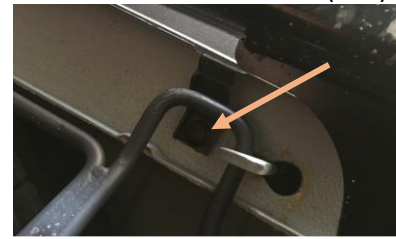

Figure 3: Plastic Rivets Underneath Bumper



Figure 4: Example of Plastic Rivet

5. Remove the side panel plastic by gently pulling away on the plastic from the vehicle to expose additional bumper attachment points. Start from the rear wheel well working towards the back of the vehicle. Reference Figure 5.

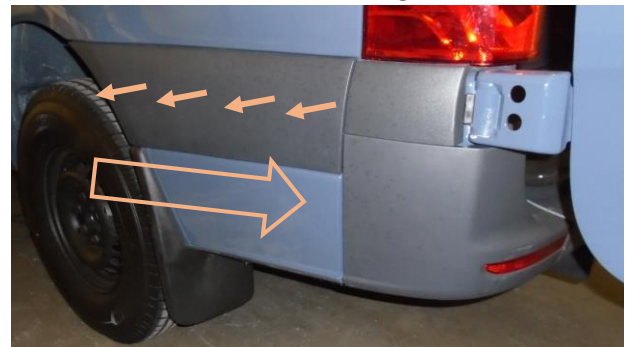

Figure 5: Side Panel Removal

6. Remove the plastic rivets anchoring the plastic rear bumper assembly on both sides of the vehicle (see Figure 6).



Figure 6: Plastic Rivets Underneath the Side Panel



- Disconnect the tabs connecting the smaller plastic panel on top from the plastic rear bumper. Once disconnected, gently pull away from vehicle to remove. Retain small panel and repeat on opposite side. Reference Figures 7-8.



Figure 7: Removing Small Plastic Panel from Rear Bumper



Figure 8: Small Plastic Panel Removed

- Remove the plastic rear bumper from the rear of the vehicle, disconnecting any wiring that has not been done so already.
- Remove blind spot assist sensor from plastic rear bumper if applicable.
- Remove the air pressure relief inserts from each side of the vehicle by squeezing each side and pulling away from the vehicle. Reference Figure 9.



Figure 9: Air Pressure Relief Insert Removal

Rear Bumper Installation:

- Install the axle support brackets (see "Additional Parts") loosely onto the axle of the rear bumper using the 3/8" x 1" bolt. Reference Figure 10.



Figure 10: Pre-Mounting Axle Support Brackets

- Install new rear bumper by lifting up to vehicle and inserting supplied 7/16" hardware through the hitch mounting locations on the vehicle. Do not yet tighten hardware.

PRO TIP: While lifting the bumper into place, shift the exhaust to allow the bumper to pass with ease.

- Position rear bumper into desired position front-to-back. Tighten the 7/16" mounting hardware to fix hitch into position. Tighten all bolts to 63 ft-lbs of torque.
- Position the axle support brackets up to the contours of the vehicle. Using the holes in bracket as a template, drill through outer surface of vehicle. Reference Figure 11.

PRO TIP: Use painter's masking tape to protect bumper as swing arm from drill.



Figure 11: Drilling for Axle Support Bracket

15. Insert and tighten all hardware on axle support bracket using provided $\frac{1}{4}$ " hardware. Use the access through the insert opening to tighten. Tighten $\frac{3}{8}$ " bolt on top of axle as well. Reference Figure 12.



Figure 12: Tightening Hardware Through Insert Opening

16. Install the trim assemblies temporarily to verify clearances around axle system and fitment onto vehicle. Reference Figure 13.



Figure 13: Installation of the Trim Assembly

PRO TIP: Mounting from the vehicle to the hitch and from the hitch to the aluminum bumper are both adjustable. Loosen associated bolts, position, and re-tighten into desired location on vehicle.

17. Re-install air pressure relief insert into opening.
18. Install blind spot assist into trim assemblies (if applicable) by sandwiching the sensor between the sensor window and the sensor bracket as shown in Figure 14.



Figure 14: Blind Spot Sensor Installation

19. Tighten the trim assemblies onto the bumper from underneath the vehicle using provided $\frac{1}{4}$ "-20 bolts, washer, and lock washer. Each trim assembly has three (3) mounting locations.
20. Re-install the plastic paneling in starting with the small upper panel. Repeat for both sides.
21. Re-install license plate onto new bumper
22. Install lights if applicable (license plate light and flush-mounted back up lights).
23. Install the factory trailer plug by lining it up with the trailer plug cutout on the bumper. Make sure the placement of the plug is lined up correctly, then center punch and drill four holes using a $\frac{5}{32}$ " drill bit. Finally, securely fasten the plug with the provided hardware use 10-32 x 1" bolts (70078), SS washers (70005), and Nylock nuts (70004). Reference Figure 15.



Figure 15: Installation of the trailer plug

wedge by hand. Once at this point tighten 2 more full rotations.

Note: Preferred torque spec. is 70 inch pounds

Tire Rack Installation:

24. Loosely fasten the Tire Mount Bracket to the slotted channel, going through the bracket first, using the 3/8" carriage head bolts, washer, and nuts to mount. Reference Figure 15.

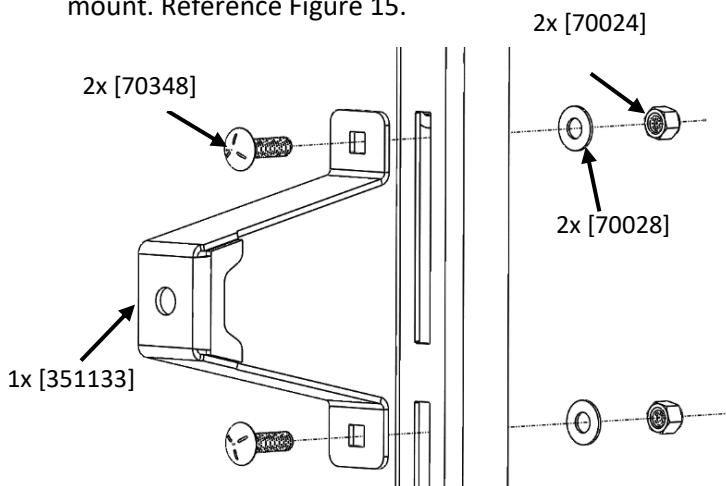

Figure 15: Mounting Tire Bracket

25. Place the mounting bracket in the correct location by placing your tire on the tire supports and then adjusting the bracket vertically until the center hub aligns with the center of the bracket.
26. Once the bracket is in place remove the tire and tighten the hardware holding the bracket in place.
27. Place the tire on the support stands and mount the wheel wedge, using the 5" hex head bolt, washer and star washer. Reference Figure 4 and 5.

NOTE: Tighten down bolt until snug with wedge (it should be very hard/near impossible to rotate the

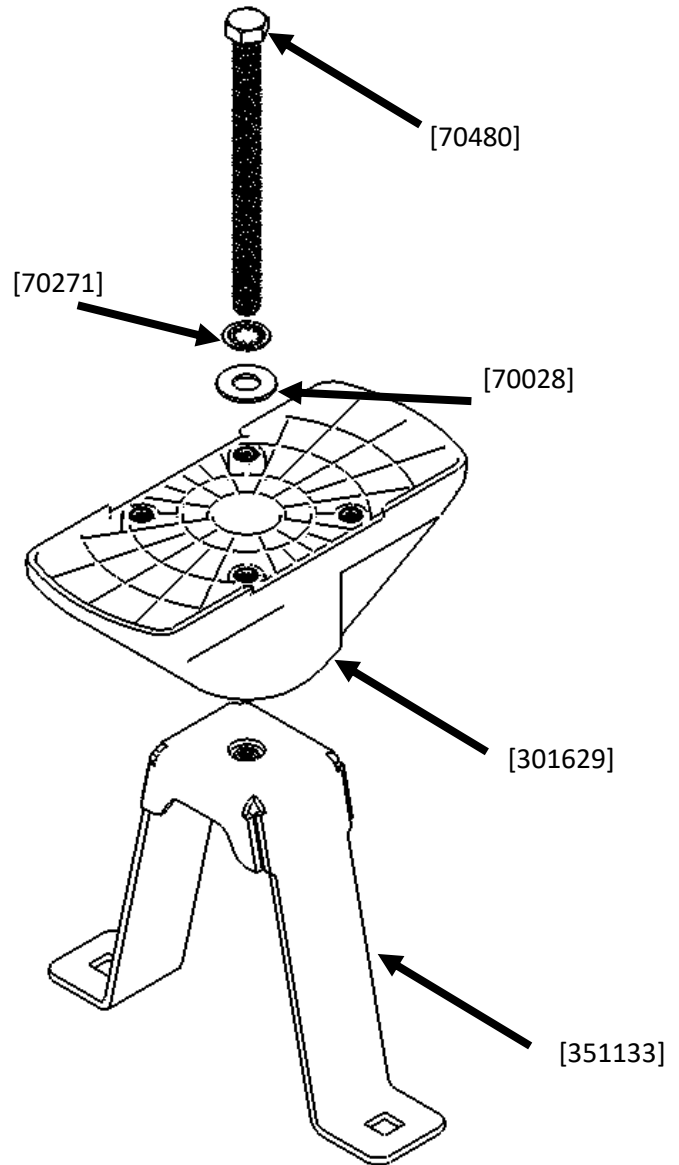

Figure 4: Wheel Wedge Assembly



Figure 5: Tire Mount Assembled

28. [Optional] If desired, you can mount a Rotopax to the wheel wedge. After installing the cover [Step 29], bolt the rotopax mount through the wheel wedge cover to the wheel wedge using the security bolts [70478], as shown below in figure 6. Then simply install the rotopax onto the mount.



Figure 6: Rotopax Mount

29. Once everything is securely fastened, bolt the cover to the wheel wedge using the included special bit [70479], and bolts [70478]. Reference Figure 7.

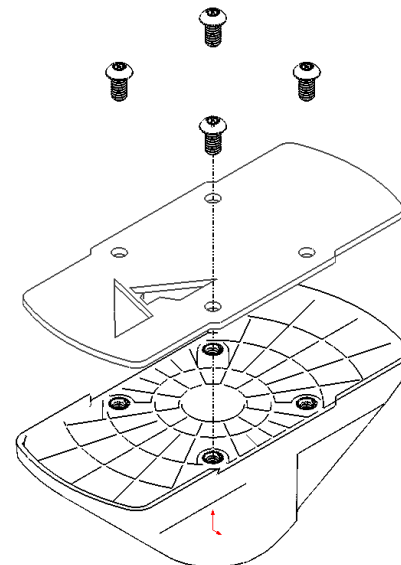

Figure 7: Wheel Wedge, Cover Mounting

30. Check mounting hardware after first 100 miles of driving and periodically after to verify hardware has not become loose from vibration.
31. Your new Aluminess bumper is now installed, enjoy!

General Torque Values			
Size	Stainless Steel	Zinc	Grade 8
#6-32	10 lb-ft	--	--
#8-32	18.4 lb-ft	--	--
#10-32	26.6 lb-ft	--	--
1/4"-20	5.3 lb-ft	7.8 lb-ft	9 lb-ft
5/16"-18	10.9 lb-ft	16 lb-ft	18 lb-ft
3/8"-16	19.4 lb-ft	28.3 lb-ft	33 lb-ft
7/16"-14	31 lb-ft	45 lb-ft	52 lb-ft
1/2"-13	47 lb-ft	69 lb-ft	80 lb-ft
M6	4.7 lb-ft	5.8 lb-ft	--
M8	11.3 lb-ft	14.1 lb-ft	--
M10	22.3 lb-ft	27.9 lb-ft	--
M12	38.9 lb-ft	48.7 lb-ft	--



Aluminess Products, Inc. (Aluminess) Warranty

1. Lifetime Warranty. Aluminess provides a lifetime warranty of its products to the original retail purchaser provided such products are installed correctly according to the official Aluminess installation instructions. Any modification to the original product design, function or use of any Aluminess products will void the Aluminess warranty. Aluminess will have sole discretion to determine warranty eligibility for any and all Aluminess products sold to any purchaser.
2. Limited Remedies. Subject to any limitations and exclusions described herein, and subject to Aluminess' determination of warranty eligibility, Aluminess will remedy defects in product materials and/or workmanship of any product by repairing or replacing such defective product, which shall be within Aluminess' sole discretion, without charge for parts or labor. Aluminess may elect in its sole discretion not to replace a defective product and issue the purchaser a refund equal to the purchase price of any defective product or purchaser may elect to receive a credit (equal to such refund) toward the purchase of new Aluminess products. Repair or replacement of a defective product or providing a refund or credit to purchaser will be purchaser's exclusive remedy under this warranty. Damage to a purchaser's vehicle, cargo and/or any other person or property is expressly excluded from the Aluminess warranty.
3. Modification. Aluminess products are designed to be mounted to factory equipped vehicles. Aftermarket additions to such vehicle may or may not require modification of an Aluminess product. The Aluminess warranty does not extend to any Aluminess products that are modified to fit around other otherwise accommodate or be compatible with any aftermarket vehicle accessories or alterations. Aluminess does not guarantee fitment with any other aftermarket accessories or modified vehicle, and it is up to purchaser to determine fitment prior to purchasing any Aluminess product.
4. Damage. Damage to Aluminess products due to normal wear and tear, including, but not limited to, cosmetic issues and superficial scratches, or structural damage to an Aluminess product in connection with any vehicle collisions or other structural degradation in connection with the use of such vehicle (on road or off road) will not be covered by the Aluminess warranty. Additionally, any product user's misuse, neglect, overloading, improper maintenance or improper installation or repair of any Aluminess products are not covered under the Aluminess warranty.
5. Use of the Products. Aluminess products are designed for off road vehicle use. Installing Aluminess products on a vehicle may exceed the factory designed capabilities of such vehicle and could potentially lead to vehicle damage. Aluminess will not be responsible for any damage caused to a purchaser or user's vehicle or any vehicle accessories caused by the use of any Aluminess products. It is to the sole responsibility of purchaser to inspect and ensure that the intended vehicle and Aluminess products are suitable and compatible for travel on road and off road. No seller nor any manufacturer of Aluminess products will be liable for any loss, damage or injury directly or indirectly arising from the use of any Aluminess products. Before using any Aluminess products, the purchaser or user will determine the suitability of the product(s) for their intended use(s) and the purchaser or user shall assume all responsibility and risk in connection therewith.
6. DISCLAIMER. THE ALUMINESS WARRANTY IS EXPRESSLY MADE IN LIEU OF ANY AND ALL OTHER WARRANTIES, AND EXCEPT FOR THE ALUMINESS WARRANTY SET FORTH HEREIN, ALUMINESS MAKES NO WARRANTY WHATSOEVER WITH RESPECT TO ANY ALUMINESS PRODUCT, INCLUDING ANY WARRANTY OF MERCHANTABILITY AND FITNESS FOR A PARTICULAR PURPOSE, WHETHER EXPRESS OR IMPLIED BY LAW, COURSE OF DEALING, COURSE OF PERFORMANCE, USAGE OF TRADE, OR OTHERWISE.

EXCEPT FOR PURCHASER'S LIMITED REMEDIES SET FORTH HEREIN, IN NO EVENT WILL ALUMINESS BE LIABLE FOR ANY LOST PROFITS, LOST SALES, OR FOR ANY CONSEQUENTIAL, DIRECT, INDIRECT, INCIDENTAL, SPECIAL, EXEMPLARY OR PUNITIVE DAMAGES OR FOR ANY OTHER DAMAGES OF ANY KIND OR NATURE.
7. Compliance. Aluminess cannot guarantee that its products comply with all Federal, State, and/or local laws. Purchaser is advised to review local vehicle codes for compatibility prior to purchase to ensure that the installation and use of any Aluminess products does not violate any applicable laws.
8. Warranty Claim Submission. Purchaser will responsible for returning any defective product to Aluminess for warranty consideration and purchaser may be responsible for all costs associated with shipping the product to and from Aluminess. Prior to returning any product for warranty, purchaser must contact Aluminess Products Inc. for proper authorization.